

Ball Screw Peripherals

Support Unit

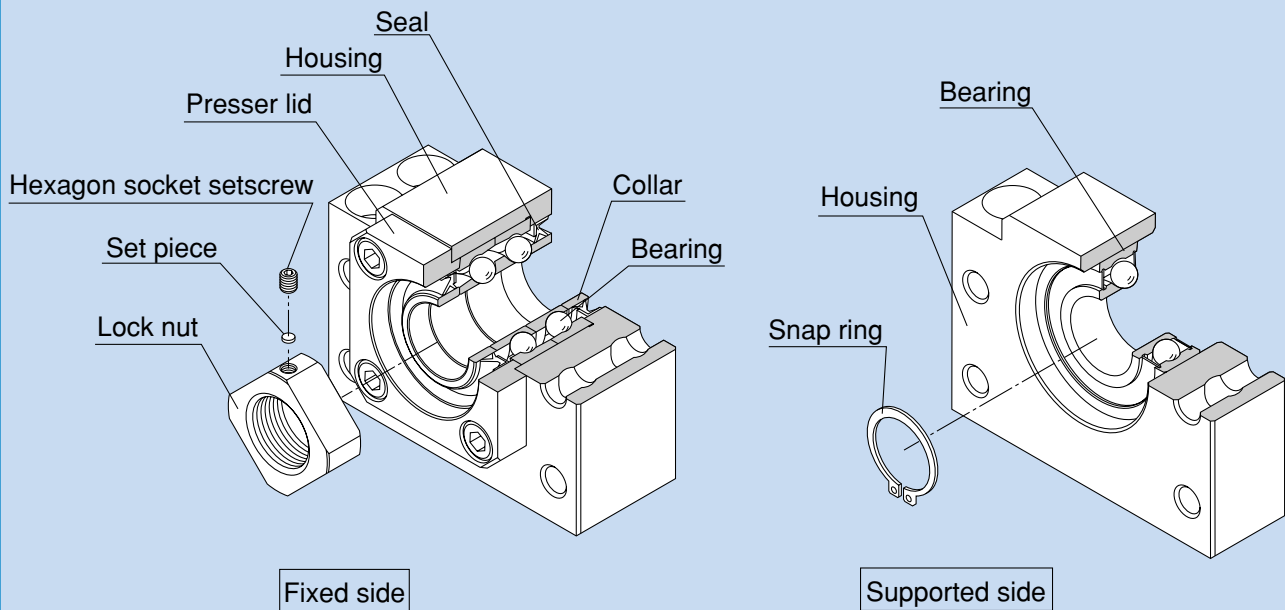

Fig. 1 Structure of the Support Unit

Structure and Features

The Support Unit comes in six types: models EK, FK, EF, and FF, which are standardized for standard-stock Ball Screws provided with finished shaft ends, and models BK and BF, which are standardized for ball screws in general.

The Support Unit on the fixed side contains a JIS Class 5-compliant angular bearing provided with an adjusted preload. The miniature type Support Unit models EK/FK 4, 5, 6 and 8, in particular, incorporate a miniature bearing with a contact angle of 45° developed exclusively for miniature Ball Screws. This provides stable rotation performance with high rigidity and accuracy.

The Support Unit on the supported side uses a deep-groove ball bearing.

The internal bearings of Support Unit models EK, FK and BK contain an appropriate amount of lithium soap-group grease that is sealed with a special seal. Thus, these models are capable of operating over a long period.

● Uses the Optimal Bearing

To ensure rigidity balance with the Ball Screw, the Support Unit uses an angular bearing (contact angle: 30° ; DF configuration) with high rigidity and low torque. Miniature Support Unit models EK/FK 4, 5, 6 and 8 are incorporated with a miniature angular bearing with a contact angle of 45° developed exclusively for miniature Ball Screws. This bearing has a greater contact angle of 45° and an increased number of balls with a smaller diameter. The high rigidity and accuracy of the miniature angular bearing provides stable rotation performance.

● Support Unit Shapes

Square and round shapes are available for the Support Unit to allow selection according to the intended use.

● Compact and Easy Installation

The Support Unit is compactly designed to accommodate the space in the installation site. As the bearing is provided with an appropriately adjusted preload, the Support Unit can be assembled with a Ball Screw unit with no further machining. Accordingly, the required man-hours in assembly can be reduced and the assembly accuracy can be increased.

● Types

For the Fixed Side

Square Type Model EK



(Inner diameter: $\phi 4$ to $\phi 20$)

Square Type Model BK



(Inner diameter: $\phi 10$ to $\phi 40$)

Round Type Model FK



(Inner diameter: $\phi 4$ to $\phi 30$)

For the Supported Side

Square Type Model EF

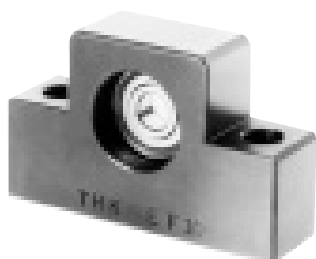

(Inner diameter: $\phi 6$ to $\phi 20$)

Square Type Model BF



(Inner diameter: $\phi 8$ to $\phi 40$)

Round Type Model FF



(Inner diameter: $\phi 6$ to $\phi 30$)

Types of Support Units and Applicable Screw Shaft Outer Diameters

Inner diameter of the fixed-side Support Unit (mm)	Applicable model No. of the fixed-side Support Unit	Inner diameter of the supported-side Support Unit (mm)	Applicable model No. of the supported-side Support Unit	Applicable screw shaft outer diameter (mm)
4	EK 4 FK 4	—	—	ø4
5	EK 5 FK 5	—	—	ø6
6	EK 6 FK 6	6	EF 6 FF 6	ø8
8	EK 8 FK 8	6	EF 8 FF 6	ø10
10	EK 10 FK 10 BK 10	8	EF 10 FF 10 BF 10	ø10, ø12, ø14
12	EK 12 FK 12 BK 12	10	EF 12 FF 12 BF 12	ø14, ø15, ø16
15	EK 15 FK 15 BK 15	15	EF 15 FF 15 BF 15	ø20
17	BK 17	17	BF 17	ø20, ø25
20	EK 20 FK 20 BK 20	20	EF 20 FF 20 BF 20	ø25, ø28, ø32
25	FK 25 BK 25	25	FF 25 BF 25	ø36
30	FK 30 BK 30	30	FF 30 BF 30	ø40, ø45
35	BK 35	35	BF 35	ø45
40	BK 40	40	BF 40	ø50

Note: The Supports Units in this table apply only to those Ball Screw models with recommended shaft ends shapes H, J and K, indicated in page k-302.

Model Numbers of Bearings and Characteristic Values

Angular ball bearing on the fixed side					Deep-groove ball bearing on the supported side			
Support Unit model No.	Bearing model No.	Axial direction			Support Unit model No.	Bearing model No.	Radial direction	
		Basic dynamic load rating Ca (kN)	*Permissible load (kN)	Rigidity (N/ μ m)			Basic dynamic load rating C (kN)	Basic static load rating Co (kN)
EK 4 FK 4	AC4-12P5	0.93	1.1	27	—	—	—	—
EK 5 FK 5	AC5-14P5	1	1.24	29	—	—	—	—
EK 6 FK 6	AC6-16P5	1.38	1.76	35	EF 6 FF 6	606ZZ	2.19	0.87
EK 8 FK 8	79M8DF GMP5	3.6	2.15	49	EF 8	606ZZ	2.19	0.87
EK10 FK10 BK10	7000HTDF GMP5	6.08	3.1	65	EF10 FF10 BF10	608ZZ	3.35	1.4
EK12 FK12 BK12	7001HTDF GMP5	6.66	3.25	88	EF12 FF12 BF12	6000ZZ	4.55	1.96
EK15 FK15 BK15	7002HTDF GMP5	7.6	4	100	EF15 FF15 BF15	6002ZZ	5.6	2.84
BK17	7203HTDF GMP5	13.7	5.85	125	BF17	6203ZZ	9.6	4.6
EK20 FK20	7204HTDF GMP5	17.9	9.5	170	EF20 FF20	6204ZZ	12.8	6.65
BK20	7004HTDF GMP5	12.7	7.55	140	BF20	6004ZZ	9.4	5.05
FK25 BK25	7205HTDF GMP5	20.2	11.5	190	FF25 BF25	6205ZZ	14	7.85
FK30 BK30	7206HTDF GMP5	28	16.3	195	FF30 BF30	6206ZZ	19.5	11.3
BK35	7207DF GMP5	37.2	5.83	255	BF35	6207ZZ	25.7	15.3
BK40	7208HTDF GMP5	44.1	27.1	270	BF40	6208ZZ	29.1	17.8

* Note: "Permissible load" indicates the static permissible load.

● Examples of Installation

Square Type Support Unit

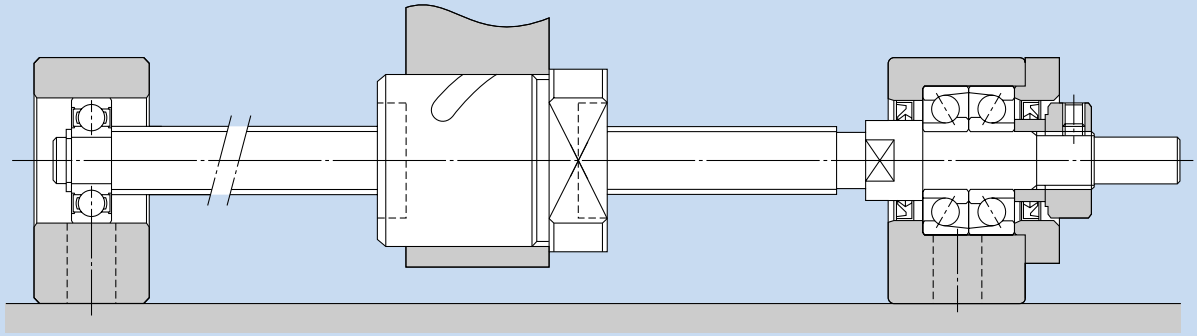

Fig. 2 Example of Installing a Square Type Support Unit

Round Type Support Unit

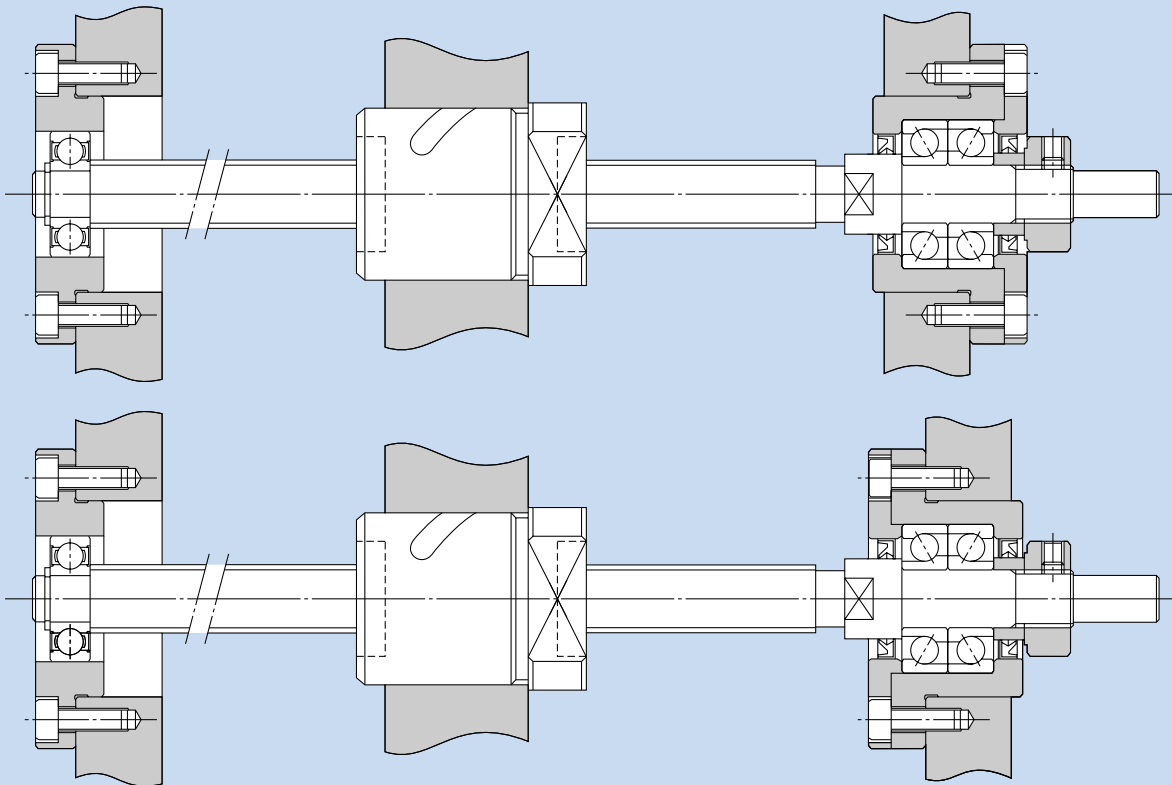

Fig. 3 Example of Installing a Round Type Support Unit

Mounting Procedure

Installing the Support Unit

- ① Install the fixed-side Support Unit with the screw shaft.
- ② After inserting the fixed-side Support Unit, secure the lock nut using the fastening set piece and hexagon socket setscrews.
- ③ Attach the supported-side bearing to the screw shaft and secure the bearing using the snap ring, and then install the assembly to the housing on the supported side.

Note 1: Do not disassemble the Support Unit.

Note 2: When inserting the screw shaft to the Support Unit, take care not to let the oil seal lip turn outward.

Note 3: When securing the set piece with a hexagon socket screw, apply an adhesive to the hexagon socket screw before tightening it in order to prevent the screw from loosening. If planning to use the product in a harsh environment, it is also necessary to take a measure to prevent other components/parts from loosening. Contact THK for details.

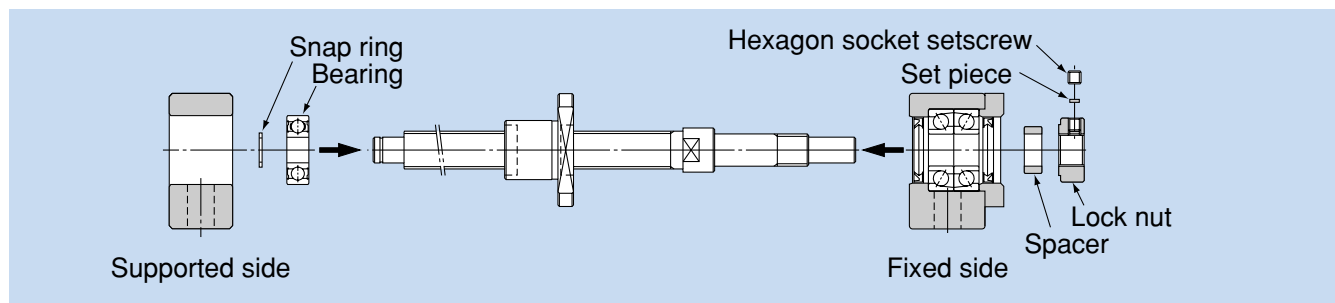

Installation onto the Table and the Base

- ① If using a bracket when mounting the ball screw nut to the table, insert the nut into the bracket and temporarily secure it.
- ② Temporarily secure the fixed-side Support Unit to the base.
 - In doing so, press the table toward the fixed-side Support Unit to align the axial center, and adjust the table so that it can freely travel.
 - If using the fixed-side Support Unit as the reference point, secure a clearance between the ball screw nut and the table or inside the bracket when making adjustment.
 - If using the table as the reference point, make adjustment either by using the shim (for a square type Support Unit), or securing a clearance between the outer surface of the nut and the inner surface of the mounting section (for a round type Support Unit).
- ③ Press the table toward the fixed-side Support Unit to align the axial center. Make adjustment by reciprocating the table several times so that the nut travels smoothly throughout the whole stroke, and temporarily secure the Support Unit to the base.

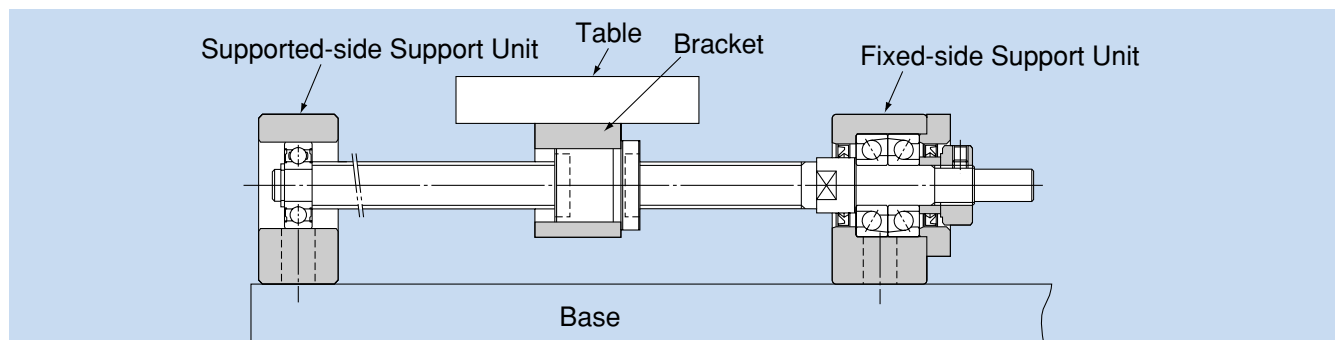

Checking the Accuracy and Fully Tightening the Support Unit

While checking the run-out of the ball screw shaft end and the axial clearance using a dial gauge, fully tighten the ball screw nut, the nut bracket, the fixed-side Support Unit and the supported-side Support Unit, in this order.

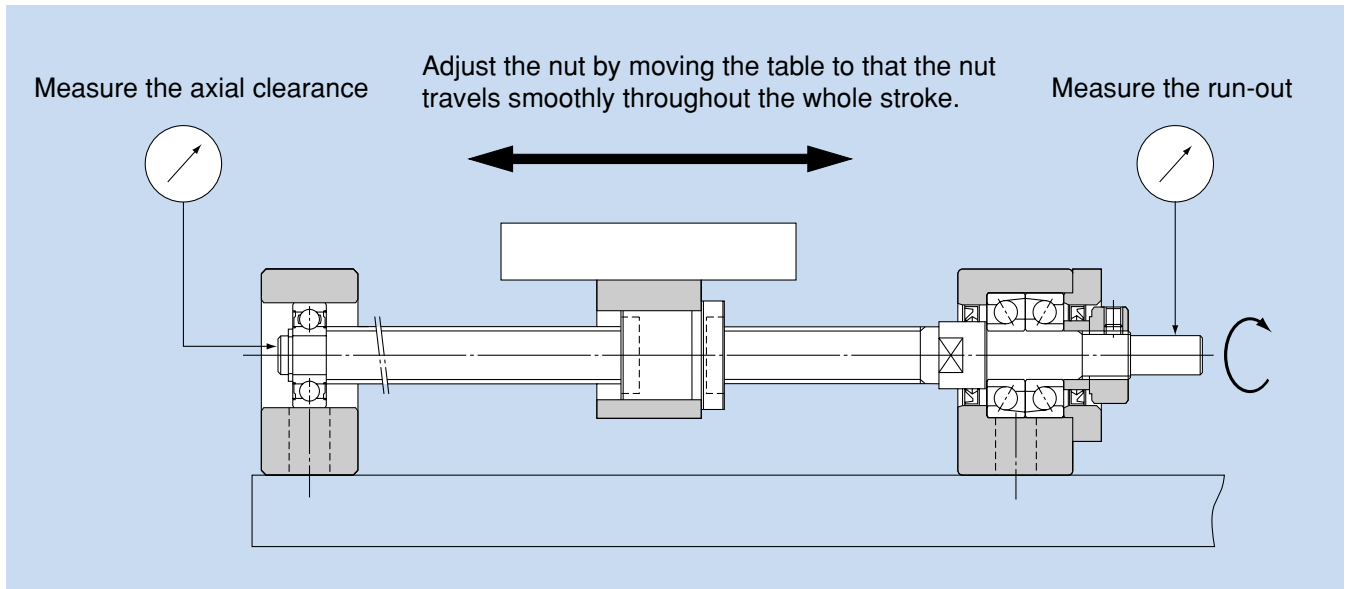

Connection with the Motor

- ① Mount the motor bracket to the base.
- ② Connect the motor and the ball screw using a coupling.
Note: Make sure the mounting accuracy is maintained.
- ③ Thoroughly perform break-in of the system.

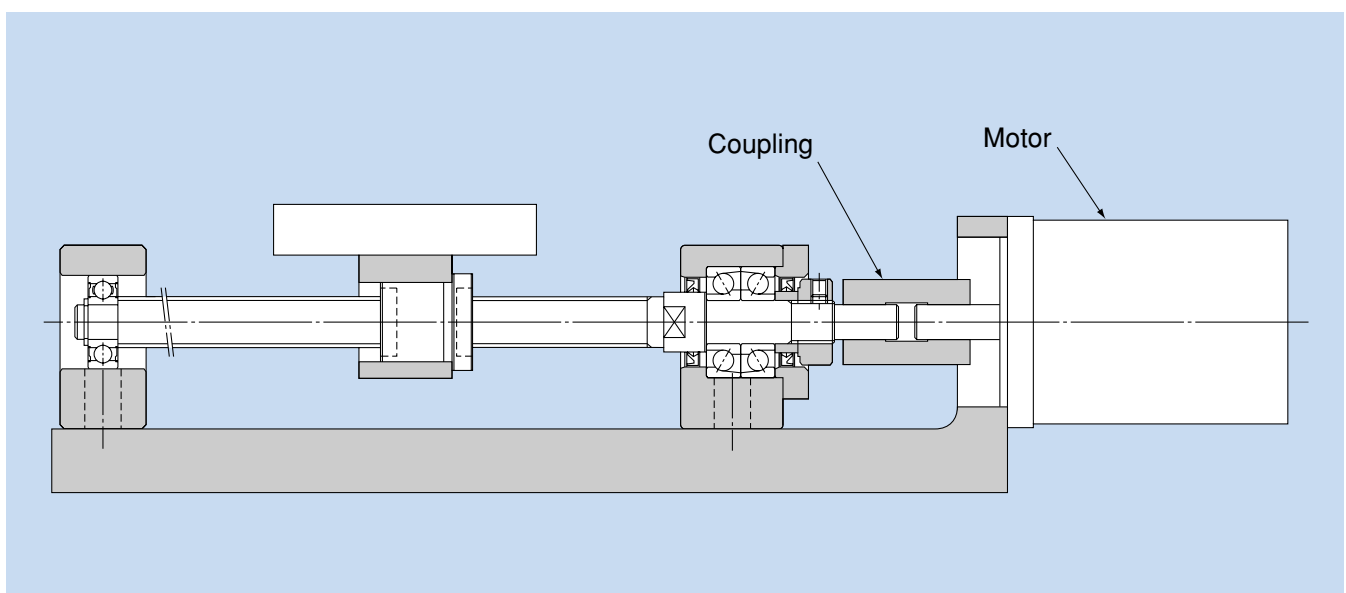

Model EK

Square Type Support Unit on the Fixed Side

K. Dimensions of the Ball Screw

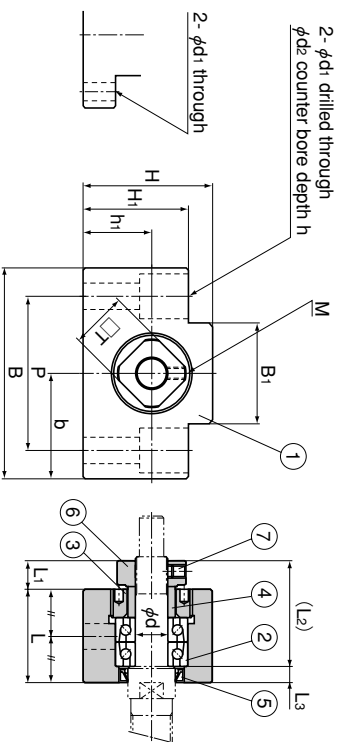

Models EK 4 and 5

Models EK 6 and 8

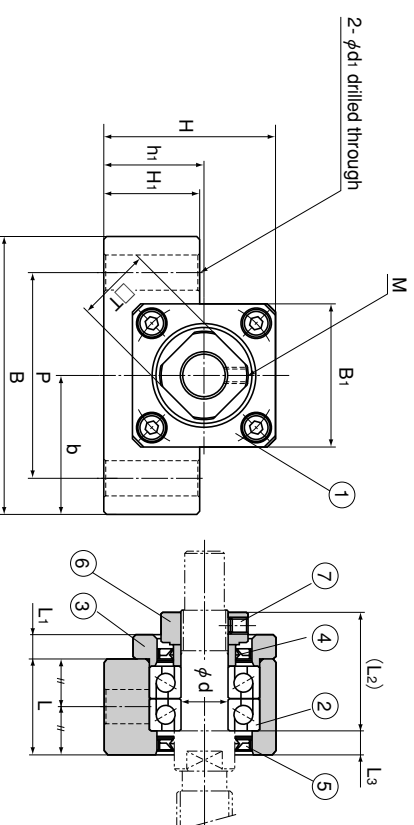

Models EK 10 to 20

Model No.	Shaft diameter d	L	L ₁	L ₂	L ₃	B	H	$\frac{D}{\pm 0.02}$	$\frac{h_1}{\pm 0.02}$	B ₁	H ₁	P	d ₁	d ₂	h	M	T	Bearing used
EK 4	4	15	5.5	17.5	3	34	19	17	10	18	7	26	4.5	—	—	M2.6	10	AC4-12P5
EK 5	5	16.5	5.5	18.5	3.5	36	21	18	11	20	8	28	4.5	—	—	M2.6	11	AC5-14P5
EK 6	6	20	5.5	22	3.5	42	25	21	13	18	20	30	5.5	9.5	11	M3	12	AC6-16P5
EK 8	8	23	7	26	4	52	32	26	17	25	26	38	6.6	11	12	M3	14	79M8DFGMP5
EK 10	10	24	6	29.5	6	70	43	35	25	36	24	52	9	—	—	M3	16	7000HTDFGMP5
EK 12	12	24	6	29.5	6	70	43	35	25	36	24	52	9	—	—	M3	19	7001HTDFGMP5
EK 15	15	25	6	36	5	80	49	40	30	41	25	60	11	—	—	M3	22	7002HTDFGMP5
EK 20	20	42	10	50	10	95	58	47.5	30	56	25	75	11	—	—	M4	30	7204HTDFGMP5

Unit: mm

Models EK 4 to 8

Part No.	Part name	No. of units
①	Housing	1
②	Bearing	1 set
③	Presser nut	1
④	Collar	2
⑤	Seal	1
⑥	Lock nut	1
⑦	Hexagon socket setscrew (with a set piece)	1

Models EK 10 to 20

Part No.	Part name	No. of units
①	Housing	1
②	Bearing	1 set
③	Presser lid	1
④	Collar	2
⑤	Seal	2
⑥	Lock nut	1
⑦	Hexagon socket setscrew (with a set piece)	1

Model BK

Square Type Support Unit on the Fixed Side

K. Dimensions of the Ball Screw

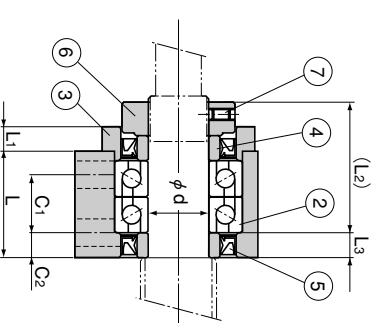
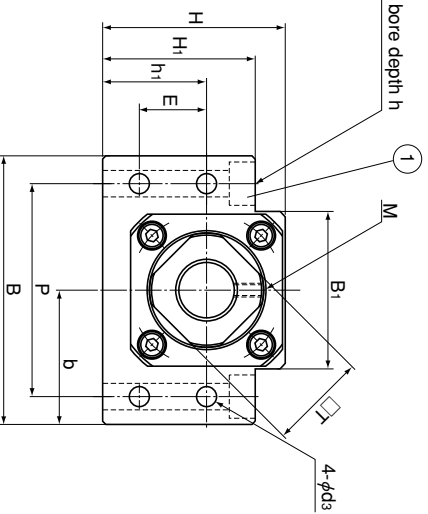

4-φd: drilled through, counter bore depth h

Model No.	Shaft diameter d	L	L ₁	L ₂	L ₃	B	H	b ±0.02	h ₁ ±0.02	B ₁	H ₁	E	P	C ₁	C ₂	d _s	d _i	d _e	h	M	T	Bearing used
BK 10	10	25	5	29	5	60	39	30	22	34	32.5	15	46	13	6	5.5	6.6	10.8	5	M3	16	7000HTDFGMPS
BK 12	12	25	5	29	5	60	43	30	25	35	32.5	18	46	13	6	5.5	6.6	10.8	1.5	M3	19	7001HTDFGMPS
BK 15	15	27	6	32	6	70	48	35	28	40	38	18	54	15	6	5.5	6.6	11	6.5	M3	22	7002HTDFGMPS
BK 17	17	35	9	44	7	86	64	43	39	50	55	28	68	19	8	6.6	9	14	8.5	M4	24	7203HTDFGMPS
BK 20	20	35	8	43	8	88	60	44	34	52	50	22	70	19	8	6.6	9	14	8.5	M4	30	7004HTDFGMPS
BK 25	25	42	12	54	9	106	80	53	48	64	70	33	85	22	10	9	11	17.5	11	M5	35	7205HTDFGMPS
BK 30	30	45	14	61	9	128	89	64	51	76	78	33	102	23	11	11	14	20	13	M6	40	7206HTDFGMPS
BK 35	35	50	14	67	12	140	96	70	52	88	79	35	114	26	12	14	14	20	13	M8	50	7207DFGMPS
BK 40	40	61	18	76	15	160	110	80	60	100	90	37	130	33	14	14	18	26	17.5	M8	50	7208HTDFGMPS

Unit: mm

Part No.	Part name	No. of units
①	Housing	1
②	Bearing	1 set
③	Presser lid	1
④	Collar	2
⑤	Seal	2
⑥	Lock nut	1
⑦	Hexagon socket setscrew (With a set piece)	1

Model FK

Round Type Support Unit on the Fixed Side

K. Dimensions of the Ball Screw

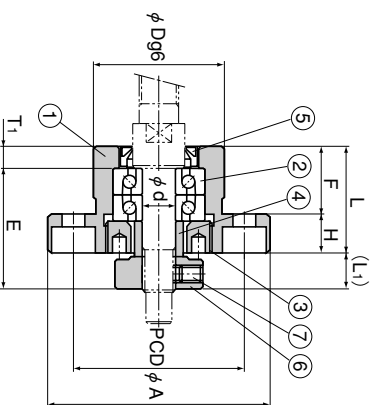

Mounting method A

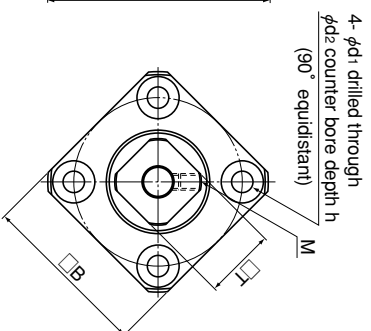

Models FK 4 to 8

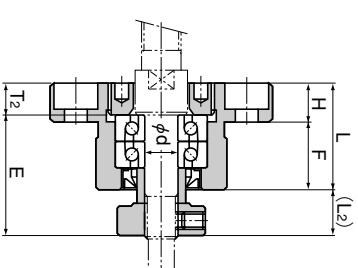

Mounting method B

Model No.	Shaft diameter d	L	H	F	E	D	A	PCD	B	Mounting method A		Mounting method B		d ₁	d ₂	h	M	T	Bearing used
										L ₁	T ₁	L ₂	T ₂						
FK 4	4	15	6	9	17.5	18 -0.010	32	24	25	5.5	3	6.5	4	3.4	6.5	4	M2.6	10	AC4-12P5
FK 5	5	16.5	6	10.5	18.5	20 -0.007	34	26	26	5.5	3.5	7	5	3.4	6.5	4	M2.6	11	AC5-14P5
FK 6	6	20	7	13	22	22 -0.007	36	28	28	5.5	3.5	8.5	6.5	3.4	6.5	4	M3	12	AC6-16P5
FK 8	8	23	9	14	26	28 -0.007	43	35	35	7	4	10	7	3.4	6.5	4	M3	14	79M8DFGMP5

Unit: mm

Part No.	Part name	No. of units
①	Housing	1
②	Bearing	1 set
③	Presser nut	1
④	Collar	2
⑤	Seal	1
⑥	Lock nut	1
⑦	Hexagon socket setscrew (with a set piece)	1

Model FK

Round Type Support Unit on the Fixed Side

K. Dimensions of the Ball Screw

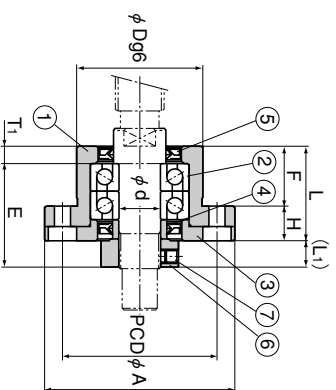

Mounting method A

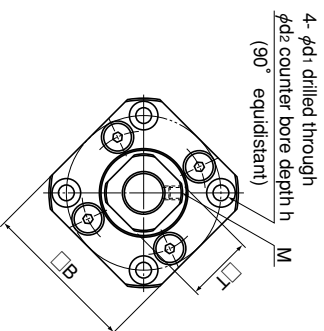

Models FK 10 to 30

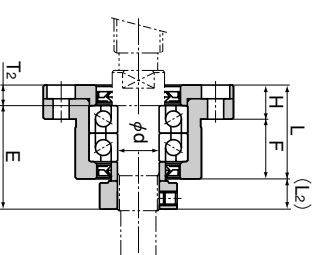

Mounting method B

Model No.	Shaft diameter d	L	H	F	E	D	A	PCD	B	Mounting method A		Mounting method B		d ₁	d ₂	h	M	T	Bearing used
										L ₁	T ₁	L ₂	T ₂						
FK 10	10	27	10	17	29.5	34 ^{-0.025}	52	42	42	7.5	5	8.5	6	4.5	8	4	M3	16	7000HTDFGMP5
FK 12	12	27	10	17	29.5	36 ^{-0.025}	54	44	44	7.5	5	8.5	6	4.5	8	4	M3	19	7001HTDFGMP5
FK 15	15	32	15	17	36	40 ^{-0.025}	63	50	52	10	6	12	8	5.5	9.5	6	M3	22	7002HTDFGMP5
FK 20	20	52	22	30	50	57 ^{-0.029}	85	70	68	8	10	12	14	6.6	11	10	M4	30	7204HTDFGMP5
FK 25	25	57	27	30	60	63 ^{-0.029}	98	80	79	13	10	20	17	9	15	13	M5	35	7205HTDFGMP5
FK 30	30	62	30	32	61	75 ^{-0.029}	117	95	93	11	12	17	18	11	17.5	15	M6	40	7206HTDFGMP5

Unit: mm

Part No.	Part name	No. of units
①	Housing	1
②	Bearing	1 set
③	Presser lid	1
④	Collar	2
⑤	Seal	2
⑥	Lock nut	1
⑦	Hexagon socket setscrew (with a set piece)	1

Model EF

Square Type Support Unit on the Supported Side

K. Dimensions of the Ball Screw

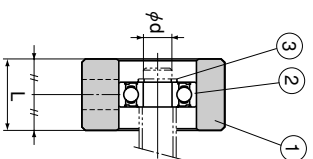
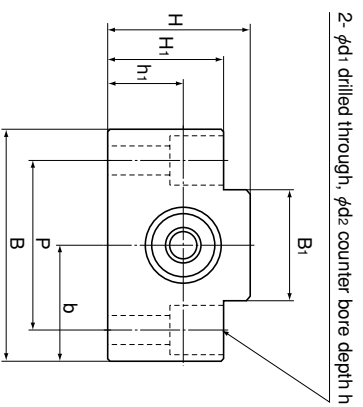

Models EF 6 and 8

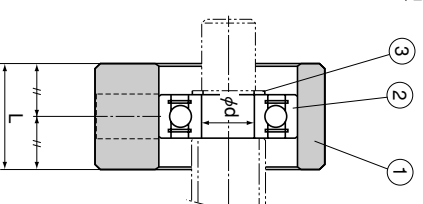
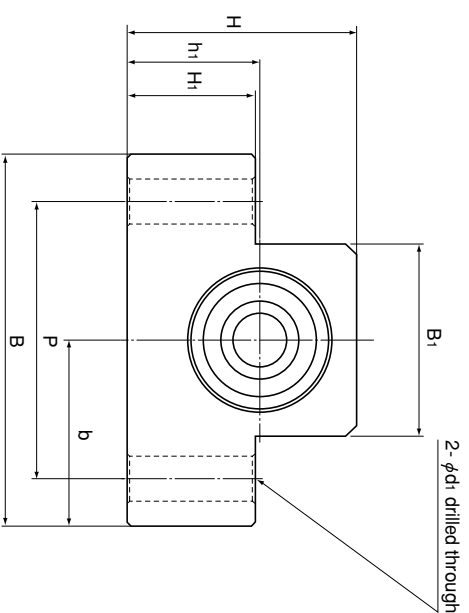

Models EF 10 to 20

Unit: mm

Model No.	Shaft diameter d	L	B	H	b ±0.02	h ₁ ±0.02	B ₁	H ₁	P	d ₁	d ₂	h	Bearing used	Snap ring used
EF 6	6	12	42	25	21	13	18	20	30	5.5	9.5	11	606ZZ	C6
EF 8	6	14	52	32	26	17	25	26	38	6.6	11	12	606ZZ	C6
EF 10	8	20	70	43	35	25	36	24	52	9	—	—	608ZZ	C8
EF 12	10	20	70	43	35	25	36	24	52	9	—	—	6000ZZ	C10
EF 15	15	20	80	49	40	30	41	25	60	9	—	—	6002ZZ	C15
EF 20	20	26	95	58	47.5	30	56	25	75	11	—	—	6204ZZ	C20

Part No.	Part name	No. of units
①	Housing	1
②	Bearing	1
③	Snap ring	1

Model BF

Square Type Support Unit on the Supported Side

K. Dimensions of the Ball Screw

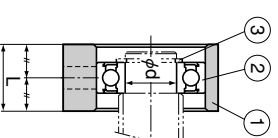
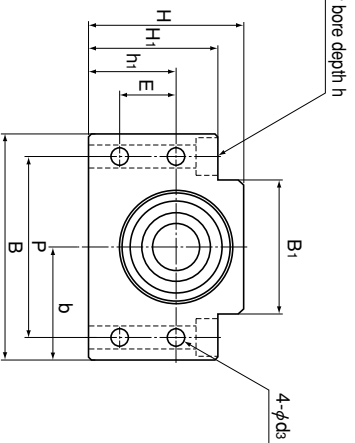

Model No.	Shaft diameter d	L	B	H	$d \pm 0.02$	$h_1 \pm 0.02$	B_1	H_1	E	P	d_s	d_1	d_2	h	Bearing used	Snap ring used
BF 10	8	20	60	39	30	22	34	32.5	15	46	5.5	6.6	10.8	5	608ZZ	C8
BF 12	10	20	60	43	30	25	35	32.5	18	46	5.5	6.6	10.8	1.5	6000ZZ	C10
BF 15	15	20	70	48	35	28	40	38	18	54	5.5	6.6	11	6.5	6002ZZ	C15
BF 17	17	23	86	64	43	39	50	55	28	68	6.6	9	14	8.5	6203ZZ	C17
BF 20	20	26	88	60	44	34	52	50	22	70	6.6	9	14	8.5	6004ZZ	C20
BF 25	25	30	106	80	53	48	64	70	33	85	9	11	17.5	11	6205ZZ	C25
BF 30	30	32	128	89	64	51	76	78	33	102	11	14	20	13	6206ZZ	C30
BF 35	35	32	140	96	70	52	88	79	35	114	11	14	20	13	6207ZZ	C35
BF 40	40	37	160	110	80	60	100	90	37	130	14	18	26	17.5	6208ZZ	C40

Unit: mm

Part No.	Part name	No. of units
①	Housing	1
②	Bearing	1
③	Snap ring	1

2-φd1 drilled through, φd2 counter bore depth h

4-φds

B_1

H

H_1

h_1

E

B

B_1

P

b

③

②

①

d_1

d_2

h

L

Model FF

Round Type Support Unit on the Supported Side

K. Dimensions of the Ball Screw

4- ϕd_1 : drilled through
 ϕd_2 : counter bore depth h
 (90° equidistant)

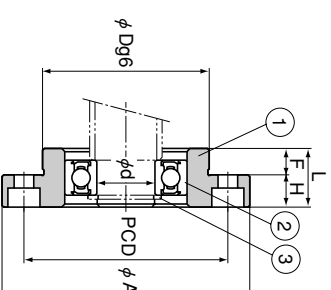
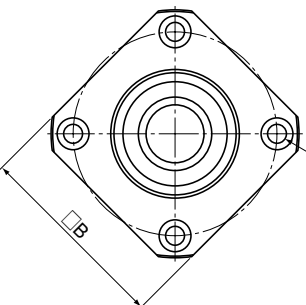

Model No.	Shaft diameter d	L	H	F	D	A	PCD	B	d _i	d _a	h	Bearing used	Snap ring used
FF 6	6	10	6	4	22 ^{-0.007}	36	28	28	3.4	6.5	4	606ZZ	C6
FF 10	8	12	7	5	28 ^{-0.007}	43	35	35	3.4	6.5	4	608ZZ	C8
FF 12	10	15	7	8	34 ^{-0.008}	52	42	42	4.5	8	4	6000ZZ	C10
FF 15	15	17	9	8	40 ^{-0.008}	63	50	52	5.5	9.5	5.5	6002ZZ	C15
FF 20	20	20	11	9	57 ^{-0.019}	85	70	68	6.6	11	6.5	6204ZZ	C20
FF 25	25	24	14	10	63 ^{-0.019}	98	80	79	9	14	8.5	6205ZZ	C25
FF 30	30	27	18	9	75 ^{-0.029}	117	95	93	11	17.5	11	6206ZZ	C30

Unit: mm

Part No.	Part name	No. of units
①	Housing	1
②	Bearing	1
③	Snap ring	1